

Last Revised: 2011-05-24 15:46:27.0

18-Slot PXI Express Chassis for PXI and PXI Express Modules

NI PXIe-1075

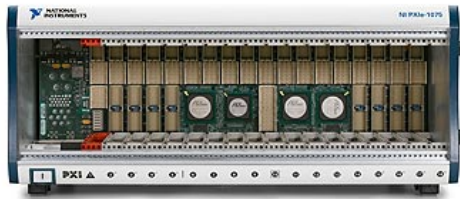

- Accepts 3U PXI, PXI Express, CompactPCI, and CompactPCI Express modules
- Up to 1 GB/s per-slot dedicated bandwidth
- 8 hybrid slots, 8 PXI Express slots, and 1 PXI Express system timing slot
- Low-jitter internal 10 MHz reference clock for PXI slots with 25 ppm stability
- Low-jitter internal 100 MHz reference clock for PXI Express slots with 25 ppm stability
- Quiet operation for 0 to 30 °C at 45 dBA
- Variable speed fan controller optimizes cooling and acoustic emissions
- Remote power-inhibit control
- Complies with PXI and CompactPCI specifications

Overview

The NI PXIe-1075 18-slot chassis features a high-bandwidth backplane with PXI Express capability in every slot to meet a wide variety of high-performance test and measurement application needs. It is ideal for high-speed measurements, data streaming, and higher-channel-density system solutions. The 0 to 55 °C extended operating temperature range provides full power and cooling to all 18 slots for demanding applications without derating. The NI PXIe-1075 also incorporates all of the timing and synchronization features defined by the latest PXI specification, including a built-in 10 MHz reference clock, PXI trigger bus, and PXI star trigger for PXI modules and a built-in 100 MHz reference clock, SYNC 100, and PXI differential star trigger for PXI Express modules.

[Back to Top](#)

Application and Technology

High Reliability

0 to 55 °C extended temperature range
791 W from 0 to 55 °C without derating
NI PXI System Monitor API for power supply, temperature, and fan monitoring
HALT- tested for increased reliability
Field-replaceable power supply shuttle

Multichassis Synchronization

PXI Express system timing slot for tight synchronization across chassis
Rear CLK10 I/O connectors
Switchless CLK10 routing

Optional Features

Front and rear rack-mount kits
Replacement power supply and fan shuttle
Filler panels
Slot blockers for improved cooling performance
Factory installation services

Slot	PXI Express System	PXI Express Peripheral	Hybrid (PXI)
Bus Signaling	PCI Express (4 x4 links) PCI (32/33)	PCI Express (x4)	PCI (32/33) PCI Express (x4)
Bandwidth (theoretical)	4 GB/s dedicated for PXI Express 132 MB/s shared for PXI	4 GB/s dedicated for PXI Express 132 MB/s shared for PXI ¹	132 MB/s shared (PXI) or 1 GB/s shared or dedicated (PXI Express)
Number of Slots	1	g ²	8

¹ Each slot provides up to 1 GB/s dedicated bandwidth; however, if more than one device is connected to the same PCI Express backplane switch, 1 GB/s is shared among those devices.

² Includes one system timing slot.

Slot Types Accept PXI and PXI Express Modules

This chassis enables higher-bandwidth systems and provides the flexibility you need to work with both PXI and PXI Express modules. There are a total of nine PXI Express slots and eight PXI hybrid-compatible slots.

The PXI Express system slot offers four x4 PCI Express links (up to 1 GB/s single direction per link) to four switches. Each switch provides a x4 PCI Express link to four or five peripheral slots. Also, each slot is capable of up to 1 GB/s per-direction dedicated bandwidth; however, if more than one device is connected to the same PCI Express backplane switch, 1 GB/s is shared among those devices.

There are also two x1 PCI Express links to two PCI Express-to-PCI translation bridges on the backplane. The PXI Express system timing slot accepts a PXI Express module or a PXI Express system timing controller for advanced timing and synchronization. The eight PXI Express hybrid slots deliver connectivity to either a x4 PCI Express link or to the 32-bit, 33 MHz PCI bus on the backplane.

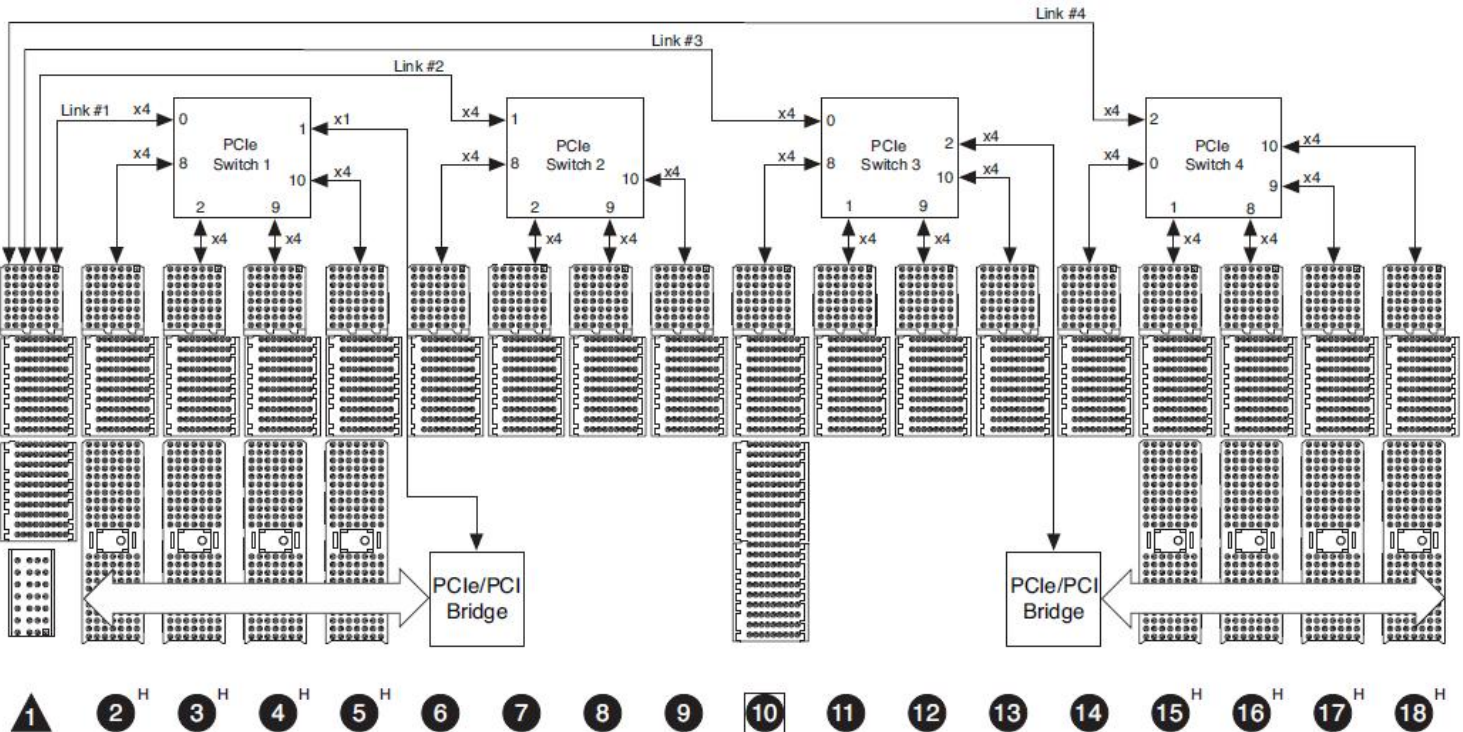

Figure 1. NI PXIe-1075 Chassis Backplane

Optimized Cooling and Acoustic Emissions

The NI PXIe-1075 chassis integrates three pulse-width modulation (PWM) system fans to provide forced-air cooling that meets the increased cooling demands of PXI Express and CompactPCI Express. The NI PXIe-1075 offers a HIGH fan setting to maximize cooling at any ambient temperature and an AUTO fan setting to minimize acoustic emissions at ambient temperatures below 30 °C. The chassis monitors air intake temperature and adjusts fan speed accordingly. With this technology, the NI PXIe-1075 achieves acoustic noise levels as low as 45 dBA (sound pressure level measured at operator position according to ISO 7779).

PXI Timing and Synchronization

For PXI modules, the NI PXIe-1075 backplane is fully compliant with PXI timing and synchronization standards. The chassis includes a 10 MHz reference clock with an accuracy of ± 25 parts per million (ppm), less than 5 ps jitter, and a maximum slot-to-slot skew of 500 ps. For triggering and handshaking needs, the NI PXIe-1075 offers the PXI trigger bus and PXI star trigger. PXI modules should be designed for use in PXI hybrid-compatible slots. Contact your local NI representative if you have any concerns.

For PXI Express modules, in addition to PXI timing and synchronization features, the NI PXIe-1075 backplane supplies a differential 100 MHz reference clock with an accuracy of ± 25 ppm, less than 3 ps jitter, and a maximum slot-to-slot skew of 100 ps. The chassis also provides differential star triggers to the PXI Express slots to offer less than 200 ps intermodule skew. With the SYNC 100, a peripheral module installed in the NI PXIe-1075 can generate its own CLK10 signal, deriving it from the 100 MHz reference clock.

Software System Configuration

The NI PXIe-1075 chassis is configured with NI Measurement & Automation Explorer (MAX). With this software configuration tool, you can easily configure NI PXIe-1075 systems without time-consuming manual installation of initialization files. MAX creates the pxisys.ini file that defines the layout and parameters of your PXI system including chassis, controller, and plug-in modules.

Replaceable Power Supply Shuttle

This chassis includes a removable high-performance universal AC power supply with built-in overcurrent protection. An isolated 12 VDC line provides power to the cooling fans, significantly reducing electrical noise on the chassis backplane. The NI PXIe-1075 incorporates the power supply and fans into a single modular unit that you can replace quickly, resulting in a mean time to repair (MTTR) of less than five minutes.

External 10 MHz Reference Clock I/O Connectors

This chassis includes IN/OUT BNC connectors for the 10 MHz reference clock on the rear of the chassis. When the backplane detects a 10 MHz signal on the IN connector, it phase locks PXI_CLK10, PXIe_CLK100, and PXIe_SYNC100 to the external clock. The OUT connector provides a buffered, non-TTL version of the 10 MHz reference clock.

Remote Power Inhibit and Monitoring

The NI PXIe- 1075 chassis features remote power inhibit and voltage monitoring through a DB-9 connector on the rear of the chassis. Use this connector to switch off power or monitor the power remotely in the chassis.

Power Supply, Temperature, and Fan Monitoring

The NI PXIe- 1075 chassis monitors power supply voltages, air intake temperature, and fan speeds; and provides any failure feedback to the user via a bicolor LED located in the power switch button on the front of the chassis

NI PXIe- 1075 Accessories

This chassis has optional accessories for complete system integration and optimized chassis functionality. Front and rear rack- mount kits are available for 19 in. rack- mounted systems. You can easily replace spare power supplies with little system downtime because of the modular nature of the NI PXIe- 1075 power supply and fan shuttle. You can use slot blockers to direct airflow inside the chassis.

[Back to Top](#)

Ordering Information

For a complete list of accessories, visit the product page on ni.com.

Products	Part Number	Recommended Accessories	Part Number
Related Accessories			
Replacement Power Supply and Fan Shuttle for NI PXIe-1075	780292-01	No accessories required.	
NI 14/18- Slot Chassis Front Rack Mount Kit	778644-01	No accessories required.	
NI PXI Slot Blocker, Set of 5	199198-01	No accessories required.	
18-Slot Chassis Filler Panel Kit (to cover 17 slots)	778646-01	No accessories required.	
PXI 18- Slot Front Panel Protector	781153-01	No accessories required.	
NI 14/18- Slot Chassis Rear Rack Mount Kit	778644-02	No accessories required.	
PXIe-1075			
PXIe- 1075, 18- Slot 3U PXI Express Chassis Requires: 1 Cable	780291-01	Cable: Shielded - Power Cord, AC, U. S., 125VAC, 15A	763830-01
		Cable: Shielded - Power Cord, 240V, 10A, North American	763068-01

[Back to Top](#)

Support and Services

System Assurance Programs

NI system assurance programs are designed to make it even easier for you to own an NI system. These programs include configuration and deployment services for your NI PXI, CompactRIO, or Compact FieldPoint system. The NI Basic System Assurance Program provides a simple integration test and ensures that your system is delivered completely assembled in one box. When you configure your system with the NI Standard System Assurance Program, you can select from available NI system driver sets and application development environments to create customized, reorderable software configurations. Your system arrives fully assembled and tested in one box with your software preinstalled. When you order your system with the standard program, you also receive system- specific documentation including a bill of materials, an integration test report, a recommended maintenance plan, and frequently asked question documents. Finally, the standard program reduces the total cost of owning an NI system by providing three years of warranty coverage and calibration service. Use the online product advisors at ni. com/advisor to find a system assurance program to meet your needs.

Technical Support

Get answers to your technical questions using the following National Instruments resources.

Support - Visit ni. com/support to access the NI KnowledgeBase, example programs, and tutorials or to contact our applications engineers who are located in NI sales offices around the world and speak the local language.

Discussion Forums - Visit forums. ni.com for a diverse set of discussion boards on topics you care about.

Online Community - Visit community. ni.com to find, contribute, or collaborate on customer- contributed technical content with users like you.

Repair

While you may never need your hardware repaired, NI understands that unexpected events may lead to necessary repairs. NI offers repair services performed by highly trained technicians who quickly return your device with the guarantee that it will perform to factory specifications. For more information, visit ni. com/repair.

Training and Certifications

The NI training and certification program delivers the fastest, most certain route to increased proficiency and productivity using NI software and hardware. Training builds the skills to more efficiently develop robust, maintainable applications, while certification validates your knowledge and ability.

Classroom training in cities worldwide - the most comprehensive hands-on training taught by engineers.

On-site training at your facility - an excellent option to train multiple employees at the same time.

Online instructor- led training - lower- cost, remote training if classroom or on- site courses are not possible.

Course kits - lowest- cost, self- paced training that you can use as reference guides.

Training memberships and training credits - to buy now and schedule training later.

Visit ni.com/training for more information.

Extended Warranty

NI offers options for extending the standard product warranty to meet the life-cycle requirements of your project. In addition, because NI understands that your requirements may change, the extended warranty is flexible in length and easily renewed. For more information, visit ni.com/warranty.

OEM

NI offers design-in consulting and product integration assistance if you need NI products for OEM applications. For information about special pricing and services for OEM customers, visit ni.com/oem.

Alliance

Our Professional Services Team is comprised of NI applications engineers, NI Consulting Services, and a worldwide National Instruments Alliance Partner program of more than 700 independent consultants and integrators. Services range from start-up assistance to turnkey system integration. Visit ni.com/alliance.

[Back to Top](#)

Detailed Specifications

This appendix contains specifications for the NI PXIe-1075 chassis.

 **Caution** Specifications are subject to change without notice.

Electrical

AC Input

Input voltage rating	100 to 120 VAC, 220 to 240 VAC
Operating voltage range ¹	90 to 120 VAC, 200 to 264 VAC
Input current rating	12 A, 6 A
Input frequency	50/60 Hz
Over-current protection	15 A circuit breaker
Line regulation	
3.3 V	<±0.2%
5 V	<±0.1%
±12 V	<±0.1%
Efficiency	70% typical
Power disconnect	The AC power cable provides main power disconnect. The front-panel power switch causes the internal chassis power supply to provide DC power to the CompactPCI/PXI Express backplane. You also can use the rear-panel D-SUB 9-pin connector and power mode switch to control the internal chassis power supply. For more information, refer to the <i>Inhibit Mode Switch</i> section of the <i>NI PXIe-1075 User Manual</i> .

DC Output

DC current capacity (I_{MP})	
Voltage	Maximum Current
+3.3 V	61 A
+5 V	48 A
+12 V	62 A
-12 V	4 A
5 V _{AUX}	2.0 A

 **Note** Maximum total power is 791 W.

Backplane pin current capacity						
Slot	+5 V	V (I/O)	+3.3 V	+12 V	-12 V	5 V _{AUX}
System Controller Slot	15 A	-	15 A	30 A	-	1 A
System Timing Slot	-	-	6 A	4 A	-	1 A
Hybrid Peripheral Slot with PXI-1 Peripheral	6 A	5 A	6 A	1 A	1 A	-
Hybrid Peripheral Slot with PXI-5 Peripheral	-	-	6 A	4 A	-	1 A



Notes Total system slot current should not exceed 45 A.

PCI V (I/O) pins in hybrid slots are connected to +5 V.

The maximum power dissipated in the system slot should not exceed 140 W.

The maximum power dissipated in a peripheral slot should not exceed 38.25 W.

Load regulation	
Voltage	Load Regulation
+3.3 V	<5%
+12 V	<5%
+5 V	<5%
-12 V	<5%

Maximum ripple and noise (20 MHz bandwidth)	
Voltage	Maximum Ripple and Noise
+3.3 V	50 mV _{pp}
+12 V	50 mV _{pp}
+5 V	50 mV _{pp}
-12 V	50 mV _{pp}

Over- current protection All outputs protected from short circuit and overload with automatic recovery

Over- voltage protection

3.3 V and 5 V Clamped at 20 to 30% above nominal output voltage

Power supply shuttle MTTR Replacement in under 5 minutes

Chassis Cooling

Module cooling system Forced air circulation (positive pressurization) through three 165 cfm fans with High/Auto speed selector

Slot airflow direction Bottom of module to top of module

Module cooling intake Bottom rear of chassis

Module cooling exhaust Along both sides and top of chassis

Power supply cooling system Forced air circulation through two integrated fans

Power supply cooling intake Right side of chassis

Power supply cooling exhaust Left side of chassis

Clearance for intake/exhaust vents 1.75 in (44.45 cm) for top and side vents, 3.00 in (76.20) for back vents

Maximum fan cleaning interval 6 months

Fan filter material 30 ppi, 3/32 in (0.24 cm) polyurethane foam. Refer to the *Cleaning the Fan Filters* section of the *NI PXIe- 1075 User Manual* for more information.

Environmental

Maximum altitude 2,000 m (800 mbar) (at 25 ° C ambient)

Pollution Degree 2

For indoor use only.

Operating Environment

Ambient temperature range 0 to 55 ° C (Tested in accordance with IEC- 60068-2- 1 and IEC- 60068-2- 2. Meets MIL-PRF- 28800F Class 3 low temperature limit and MIL- PRF- 28800F Class 2 high temperature limit.)

Relative humidity range 10 to 90%, noncondensing (Tested in accordance with IEC- 60068-2- 56.)

Storage Environment

Ambient temperature range -40 to 71 ° C (Tested in accordance with IEC- 60068-2- 1 and IEC- 60068-2- 2. Meets MIL-PRF- 28800F Class 3 limits.)

Relative humidity range 5 to 95%, noncondensing (Tested in accordance with IEC- 60068-2- 56.)

Shock and Vibration

Operational shock	30 g peak, half- sine, 11 ms pulse (Tested in accordance with IEC- 60068-2-27. Meets MIL-PRF- 28800F Class 2 limits.)
Random Vibration	5 to 500 Hz, 0.3 g _{rms}

Acoustic Emissions

Sound Pressure Level (at Operator Position)

(Tested in accordance with ISO 7779. Meets MIL-PRF- 28800F requirements.)

Auto fan (up to ~30 °C ambient)	45.0 dBA
High fan	63.3 dBA

Sound Power

Auto fan (up to ~30 °C ambient)	55.5 dBA
High fan	76.2 dBA

 **Note** For EMC compliance, operate this device according to the documentation. In addition, all covers and filler panels must be installed.

Specifications are subject to change without notice.

Safety Standards

This product is designed to meet the requirements of the following standards of safety for electrical equipment for measurement, control, and laboratory use:

IEC 61010-1, EN 61010- 1
UL 61010- 1, CSA 61010-1

 **Note** For UL and other safety certifications, refer to the product label or the *Online Product Certification* section.

Electromagnetic Compatibility

This product is designed to meet the requirements of the following standards of EMC for electrical equipment for measurement, control, and laboratory use:

EN 61326 EMC requirements; Minimum Immunity
EN 55011 Emissions; Group 1, Class A
AS/NZS CISPR 11: Group 1, Class A emissions
FCC 47 CFR Part 15B: Class A emissions
ICES- 001: Class A emissions

 **Note** For EMC compliance, operate this device with shielded cables.

 **Note** For the standards applied to assess the EMC of this product, refer to the Online Product Certification section.

CE Compliance

This product meets the essential requirements of applicable European Directives, as amended for CE marking, as follows:

2006/95/EC; Low- Voltage Directive (safety)
2004/108/EC; Electromagnetic Compatibility Directive (EMC)

Online Product Certification

Refer to the product Declaration of Conformity (DoC) for additional regulatory compliance information. To obtain product certifications and the DoC for this product, visit ni.com/certification, search by module number or product line, and click the appropriate link in the Certification column.

Environmental Management

National Instruments is committed to designing and manufacturing products in an environmentally responsible manner. NI recognizes that eliminating certain hazardous substances from our products is beneficial not only to the environment but also to NI customers.

For additional environmental information, refer to the *NI and the Environment* Web page at ni.com/environment. This page contains the environmental regulations and directives with which NI complies, as well as other environmental information not included in this document.

Waste Electrical and Electronic Equipment (WEEE)

 **EU Customers** At the end of the product life cycle, all products *must* be sent to a WEEE recycling center. For more information about WEEE recycling centers, National Instruments WEEE initiatives, and compliance with WEEE Directive 2002/96/EC on Waste Electrical and Electronic Equipment, visit ni.com/environment/weee.htm.





电子信息产品污染控制管理办法（中国 RoHS）



中国客户 National Instruments 符合中国电子信息产品中限制使用某些有害物质指令 (RoHS)。
关于 National Instruments 中国 RoHS 合规性信息, 请登录 ni.com/environment/rohs_china。
(For information about China RoHS compliance, go to ni.com/environment/rohs_china.)

Backplane

Size	3U- sized; one system slot (with three system expansion slots) and 17 peripheral slots. Compliant with IEEE 1101.10 mechanical packaging. PXI Express Specification compliant. Accepts both PXI Express and CompactPCI (PICMG 2.0 R 3.0) 3U modules.
------	--

Backplane bare-board material	UL 94 V-0 Recognized
Backplane connectors	Conforms to IEC 917 and IEC 1076-4-101, and are UL 94 V-0 rated
System Synchronization Clocks (PXI_CLK10, PXIe_CLK100, PXIe_SYNC100)	
10 MHz System Reference Clock: PXI_CLK10	
Maximum slot-to-slot skew	500 ps
Accuracy	±25 ppm max. (guaranteed over the operating temperature range)
 Note The 10 MHz system reference clock does not require calibration.	
Maximum jitter	5 ps RMS phase-jitter (10 Hz–1 MHz range)
Duty-factor	45%–55%
Unloaded signal swing	3.3 V ±0.3 V
 Note For other specifications refer to the <i>PXI-1 Hardware Specification</i> .	
100 MHz System Reference Clock: PXIe_CLK100 and PXIe_SYNC100	
Maximum slot-to-slot skew	100 ps
Accuracy	±25 ppm max. (guaranteed over the operating temperature range)
Maximum jitter	3 ps RMS phase-jitter (10 Hz–12 kHz range) 2 ps RMS phase-jitter (12 kHz–20 MHz range)
Duty-factor for PXIe_CLK100	45%–55%
Absolute single-ended voltage swing (When each line in the differential pair has 50 Ω termination to 1.30 V or Thévenin equivalent)	400–1000 mV
 Note For other specifications refer to the <i>PXI-5 PXI Express Hardware Specification</i> .	
External 10 MHz Reference Out (BNC on rear panel of chassis)	
Accuracy	±25 ppm max. (guaranteed over the operating temperature range)
Maximum jitter	5 ps RMS phase-jitter (10 Hz–1 MHz range)
Output amplitude	1 V _{PP} ±20% square-wave into 50 Ω 2 V _{PP} unloaded
Output impedance	50 Ω ±5 Ω
External Clock Source	
Frequency	10 MHz ±100 PPM
Input amplitude	
Rear panel BNC	200 mV _{PP} to 5 V _{PP} square-wave or sine-wave
System timing slot PXI_CLK10_IN	5 V or 3.3 V TTL signal
Rear panel BNC input impedance	50 Ω ±5 Ω
Maximum jitter introduced by backplane	1 ps RMS phase-jitter (10 Hz–1 MHz range)
PXIe_SYNC_CTRL	
V _{IH}	2.0–5.5 V
V _{IL}	0–0.8 V
PXI Star Trigger	
Maximum slot-to-slot skew	250 ps
Backplane characteristic impedance	65 Ω ±10%
 Note	
For PXI slot to PXI Star mapping refer to the <i>System Timing Slot</i> section of the <i>NI PXIe-1075 User Manual</i> . For other specifications refer to the <i>PXI-1 Hardware Specification</i> .	
PXI Differential Star Triggers (PXIe-DSTARA, PXIe-DSTARB, PXIe-DSTARC)	
Maximum slot-to-slot skew	150 ps
Maximum differential skew	25 ps

Note

For PXIe slot to PXI_DSTAR mapping refer to the *System Timing Slot* section of the *NI PXIe- 1075 User Manual*. For other specifications, the NI PXIe- 1075 complies with the *PXI-5 PXI Express Hardware Specification*.

Mechanical

Overall dimensions

Standard chassis

Height	6.97 in. (177.1 mm)
Width	18.30 in. (464.8 mm)
Depth	18.40 in. (467.4 mm)

Note 0.57 in. (14.5 mm) is added to height when feet are installed. When tilted with front feet extended on table top, height is increased approximately 2.08 in. (52.8 mm) in front and 0.583 in. (14.8 mm) in rear.

Weight	14.06 kg (31.0 lb)
--------	--------------------

Chassis materials	Sheet Aluminum (5052- H32, 3003- H14, and 6061- T6), Extruded Aluminum (6060- T6), and Cold Rolled Steel, PC-ABS, Santoprene, Nylon
-------------------	---

Finish	Conductive Clear Iridite on Aluminum, Electroplated Nickel on Cold Rolled Steel, Polyurethane Enamel
--------	--

The following two figures show the NI PXIe- 1075 chassis dimensions. The holes shown are for the installation of the optional rack mount kits. You can install those kits on the front or rear of the chassis, depending on which end of the chassis you want to face toward the front of the instrument cabinet. Notice that the front and rear chassis mounting holes (size M4) are symmetrical.

NI PXIe- 1075 Chassis Dimensions (Front and Side)

Dimensions are in inches (millimeters)

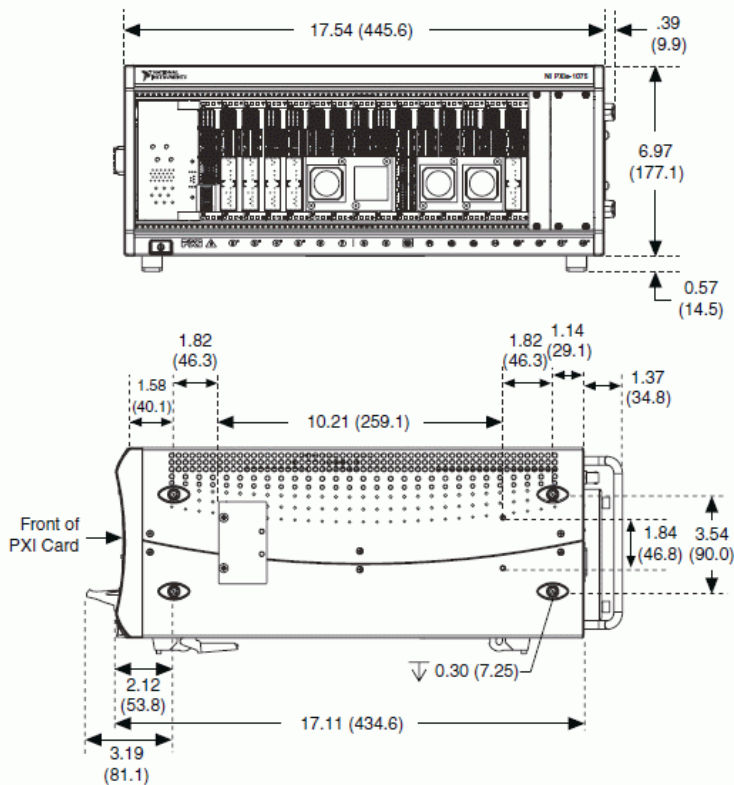

NI PXIe- 1075 Chassis Dimensions (Bottom)

Dimensions are in inches (millimeters)

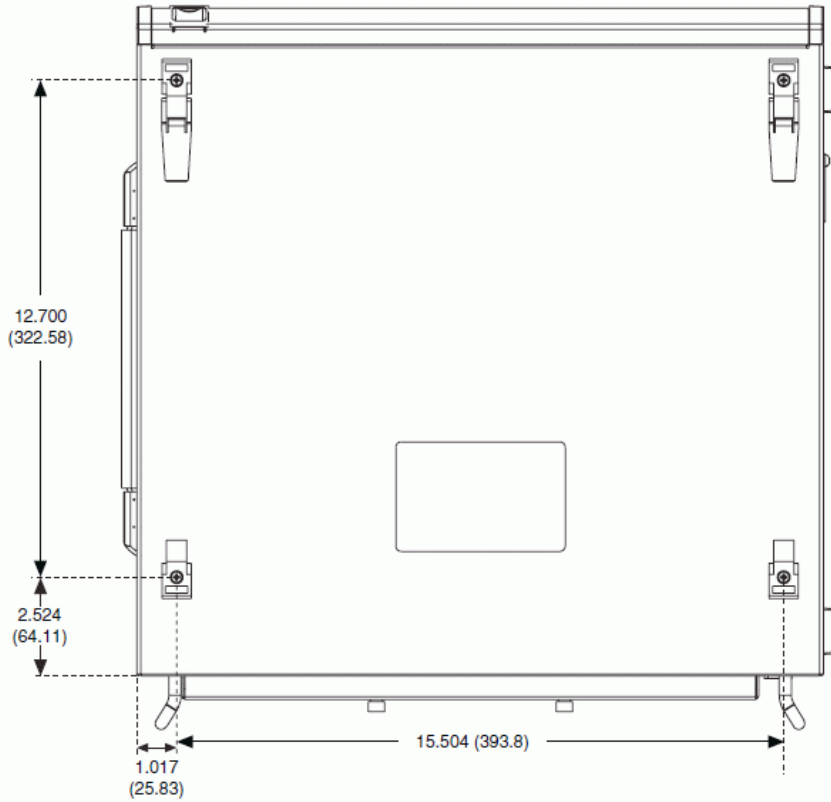

The following figure shows the chassis rack mount kit components.

NI Chassis Rack Mount Kit Components

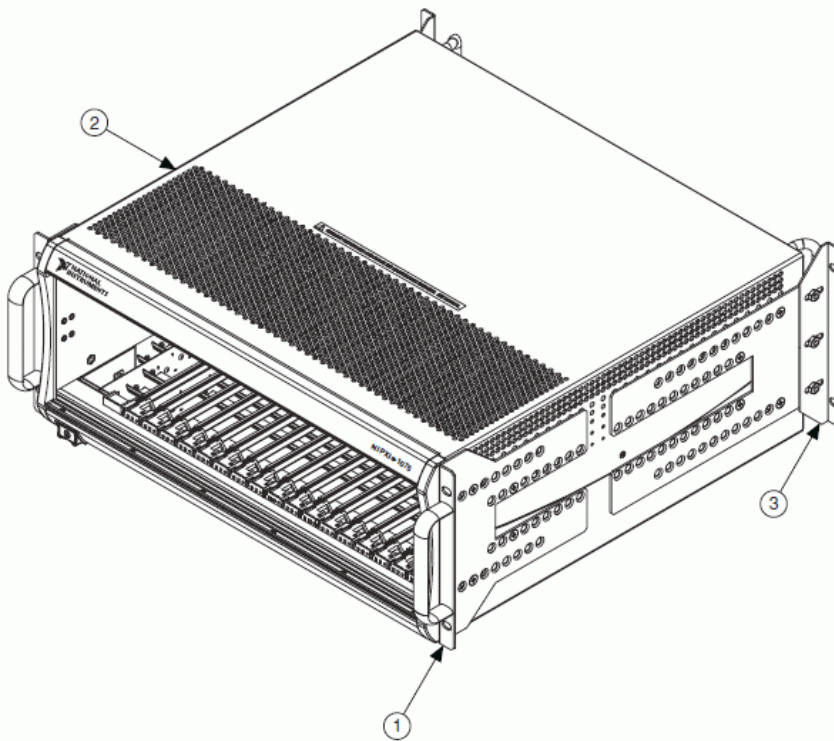

1 Front Rack Mount Kit 2 NI Chassis 3 Optional Rear Rack Mount Kit



Note The chassis shown in the previous figure is representative of the NI PXI- 1044/1045 and NI PXIe- 1075 product line. For more information on rack mounting the NI PXIe- 1075 chassis, refer to the printed installation guide included with your rack mount kit.

¹ The operating range is guaranteed by design.

©2010 National Instruments. All rights reserved. CompactRIO, CVI, FieldPoint, LabVIEW, National Instruments, National Instruments Alliance Partner, NI, ni. com, NI-DAQ, and NI TestStand are trademarks of National Instruments. The mark LabWindows is used under a license from Microsoft Corporation. Windows is a registered trademark of Microsoft Corporation in the United States and other countries. Other product and company names listed are trademarks or trade names of their respective companies. A National Instruments Alliance Partner is a business entity independent from National Instruments and has no agency, partnership, or joint-venture relationship with National Instruments.

[My Profile](#) | [RSS](#) | [Privacy](#) | [Legal](#) | [Contact NI](#) © 2012 National Instruments Corporation. All rights reserved.