

Quality is more than a word

ESPEC

Bench-Top Type Temperature (& Humidity) Chamber

SH·SU

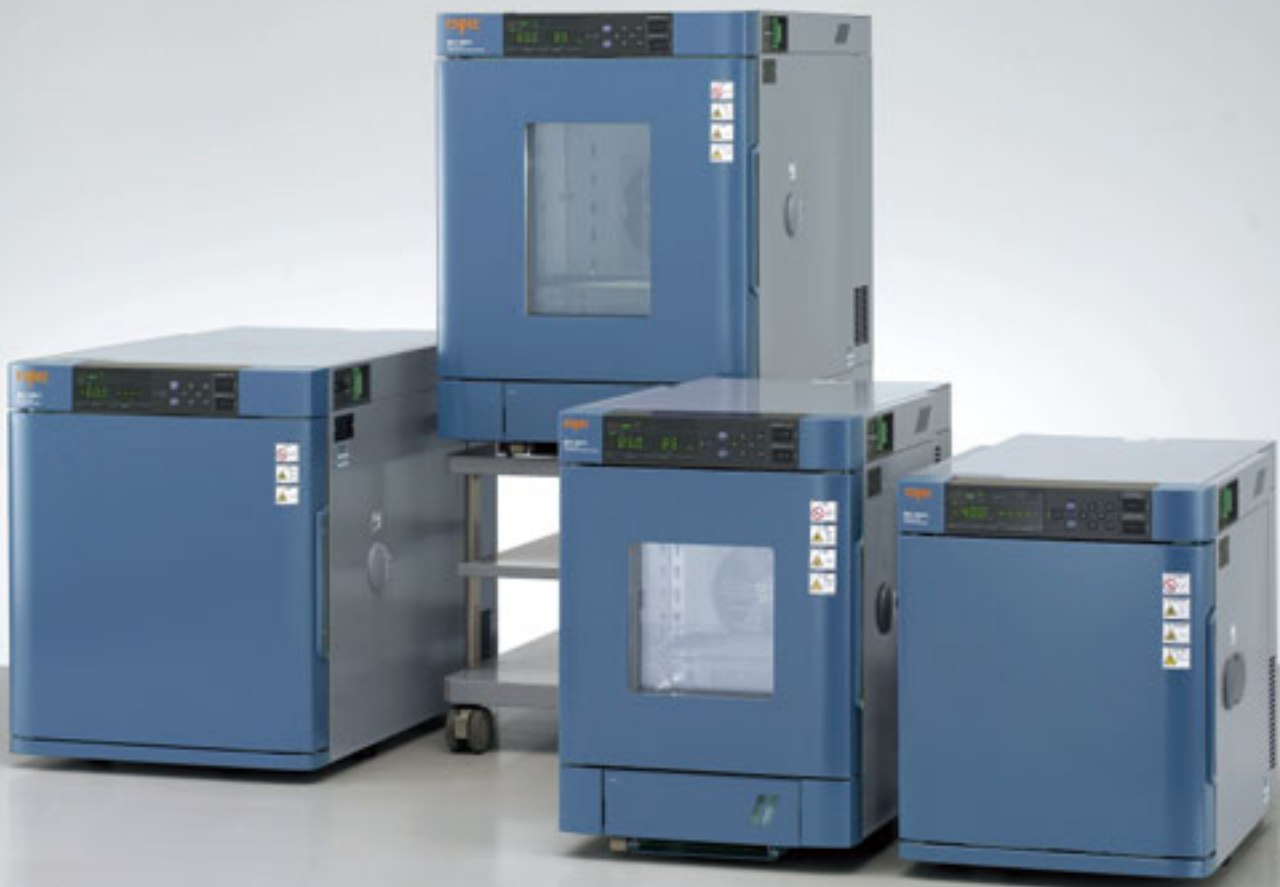

Compact design for personal use, to network with your computer.

The Bench-top Type Temperature (& Humidity) Chamber Series features environmental testing performance in a compact design. Available in 20L and 60L capacities, these models offer temperature ranges as low as -20 , -40 , or -60°C , and achieve excellent performance rates, as well as communication interface compatibilities to collect test data.

Espec offers you the best in terms of advanced testing equipment.





* The viewing window is optional.

Characteristics



Stacked chambers (on stands)



Test area (60L model)



● Full variation to select from

With its 3 temperature range patterns (to -60 , -40 or -20°C), and 2 volumes (20 and 60L) selection, the Bench-top chambers offer 10 models in temperature or temperature/ humidity configuration, to fulfill customers' needs.

● Light and small structure

The chamber structure is optimized to save space while offering a wide test area (22.5L for 1st model). Its relatively light weight allows setup almost everywhere.

● Full-size chamber performance in a compact design

The SH-661 model achieves -60 to $+150^{\circ}\text{C}$ temperature range and 30 to 95%rh for humidity in a small structure. It shows undoubtedly better performance than any other previous bench-top model.

● A refrigeration system that reduces energy consumption by 55%

Our exclusive refrigerator system with capacity control achieves 55% reduction in power consumption compared to our previous model. (SH/SU-221·241 models)

● Easy wiring access

The chamber features free access to the test area. Cable ports are provided on both right and left side to allow easy wiring of specimens for measurement or voltage application.

Characteristics

- **Layout arrangement thanks to additional stand (option)**

L and H stands are equipped with casters, and allow easy storage to optimize your testing zone. L stand is lower to fit under H stand and stack chambers. (L=Low, H=High)

* It is recommended to secure stands to the floor with provided anchor bolts.

- **Easy water supply**

Water is supplied from the front side tank (equipped with a level sensor). Auxiliary water tank circuit (option) is also available for extended operation time. (SH model)

- **Right-opening door (option)**

The door opening can be reversed to fit your installation space.

- **Viewing window (option)**

An optional viewing window can be added to check specimens and wiring during testing.

(W215×H215mm for 20L model, W215×H315mm for 60L model)

* Standard performance of the chamber will not be met when adding this option.



Stands (option)



Water supply tank



Right-opening door (option)



Viewing window (option)

Characteristics



Example: Bench-top Type Temperature (& Humidity) Chamber connected with the Ion Migration Evaluation System (sold separately)



Paperless recorder Portable type (option)



Cable port plug (Material marked)

- **Ion migration evaluation**

The Bench-top chamber can be combined with ESPEC's Ion Migration Evaluation System (AMI) to ensure even more accurate evaluation results.

- **Paperless recorder (option)**

Portable type, to record temperatures from various sources, such as test area temperature. Recording is possible on Compact Flash Card or via USB port.

- **Material labeling for easy recycling**

Plastic molded components are labeled and easily detachable to make recycling easier for future disposal of the equipment.

Control operation



Key input setting

Easy setting of temperature and humidity values, but also upper and lower temperature (& humidity) limit alarms, by mechanical key input.

Program operation up to 9 steps

Besides constant setting, program operation is available by setting different patterns (9 step/ pattern) of heat up and pull down temperatures, to meet requirements of temperature characteristic test or temperature (& humidity) cycling. The instrumentation additionally offers various functions.

Flexible communication interface

An RS-485 connector is equipped as standard, but RS-232C or GP-IB is also available as option.

Remote control from your PC

Using "WEB Manager" (converter sold separately) and an intranet to connect the chamber and a computer makes it possible to edit profiles and perform monitoring from the computer.

Description of program function

Program function	Pattern
Step program	
Temperature gradient program	
Termination program	

*1 Sets a program repetition frequency between a range of 1 and 99.

*2 Selects HOLD, CONST or OFF when a program is over.

Temperature (& humidity) program indicator controller

Setting	Mechanical key input
Display	7 segment LED display
Operating mode	Program operation, constant operation
Control	PID control
Setting and indication	Temp. : 0.1°C Humid. : 1%rh (SH only) Time : 1 minute
Setting and indication ranges	Temp. : -25 to +155°C (SH-221, SU-221) -45 to +155°C (SH-241/641, SU-241/641) -65 to +155°C (SH-261/661, SU-261/661) Humid. : 0 to 100%rh (SH only) Time : 0 to 99 hours 59 minutes, 100 to 999 hours
Indication accuracy *	Temp. : 0.5°C (Typ.) Humid. : ±2%rh (Typ.) (SH only) Time : within 30 sec. per month
Program memory capacity	9 steps per pattern (1 to 99 times)
Interface	RS-485
Auxiliary functions	Input-burnout detection Upper and lower temp. (& humid.) limit alarm Self-diagnostic (watchdog timer) Alarm indication Power cut protection Refrigerator capacity automatic control
Battery	Lithium battery × 1

* At ambient temperature +23°C

Model	SH-221	SH-241	SH-261	SH-641	SH-661		
System	Balanced Temperature & Humidity Control system (BTHC system)						
Temp. performance ¹	Temp. range	-20 to +150°C (-4 to +302°F)	-40 to +150°C (-40 to +302°F)	-60 to +150°C (-76 to +302°F)	-40 to +150°C (-40 to +302°F)	-60 to +150°C (-76 to +302°F)	
	Temp. fluctuation	±0.3°C (-20 to +100°C) ±0.5°C (+100.1 to +150°C)	±0.3°C (-40 to +100°C) ±0.5°C (+100.1 to +150°C)	±0.3°C (-60 to +100°C) ±0.5°C (+100.1 to +150°C)	±0.3°C (-40 to +100°C) ±0.5°C (+100.1 to +150°C)	±0.3°C (-60 to +100°C) ±0.5°C (+100.1 to +150°C)	
	Temp. gradient / Temp. variation in space	2.5°C (-20 to +100°C) 4.0°C (+100.1 to +150°C)	2.5°C (-40 to +100°C) 4.0°C (+100.1 to +150°C)	2.5°C (-60 to +100°C) 4.0°C (+100.1 to +150°C)	2.5°C (-40 to +100°C) 4.0°C (+100.1 to +150°C)	2.5°C (-60 to +100°C) 4.0°C (+100.1 to +150°C)	
	Temp. rate of change	Heat up rate	3.2°C /min.	3.2°C /min.	3.2°C /min.	2.9°C /min.	2.9°C /min.
		Pull down rate	2.1°C /min.	2.1°C /min.	2.1°C /min.	1.7°C /min.	1.7°C /min.
	Heat up time	From -20 to +150°C within 55 min.	From -40 to +150°C within 60 min.	From -60 to +150°C within 70 min.	From -40 to +150°C within 70 min.	From -60 to +150°C within 80 min.	
	Temp. extreme achievement time Pull down time	From +20 to -20°C within 20 min.	From +20 to -40°C within 50 min.	From +20 to -60°C within 70 min.	From +20 to -40°C within 60 min.	From +20 to -60°C within 90 min.	
Lowest attainable temp.	-20°C	-40°C	-60°C	-40°C	-60°C		
Humid. performance ¹	Humid. range	30 to 95% rh (Refer to diagram on page 9)					
	Humid. fluctuation	±3.0% rh					
Construction	Heater	Nichrome strip wire heater					
	Humidifier	Sheathed heater					
	Refrigeration unit	System	Mechanical single-stage refrigeration system		Mechanical cascade refrigeration system		
		Cooler	Plate fin cooler				
	Refrigerator	Hermetically sealed compressor, Air-cooled condenser, Expansion mechanism: Capillary tube system					
	Refrigerator capacity	400W		[Unit 1: 400W ×1, Unit 2: 400W ×1]			
Refrigerant	R404A		R23, R404A				
Capacity	22.5 L			64 L			
Chamber total load resistance	20 kg						
Inside dimensions mm (inch) ²	W300×H300×D250 (W11.81×H11.81×D9.84)			W400×H400×D400 (W15.75×H15.75×D15.75)			
Outside dimensions mm (inch) ²	W440×H630×D695 (W17.32×H24.80×D27.36)		W440×H690×D785 (W17.32×H27.18×D30.91)	W540×H730×D920 (W21.26×H28.74×D36.22)			
Weight	83 kg (78 for 100V type)		105 kg	130 kg			
Utility requirements	Allowable ambient conditions	+5 to +35°C (+41 to +95°F)					
	Power supply ³	100V AC 1φ50/60Hz	13.5 A	15.0 A	18.0 A		
		115V AC 1φ60Hz	13.0 A	14.5 A	—		
		200V AC 1φ50/60Hz	—		10.5 A		
		220V AC 1φ50/60Hz	8.0 A	9.5 A	10.0 A		
		220V AC 1φ60Hz ⁴	8.0 A	9.5 A	10.0 A		
		230V AC 1φ50Hz ⁴	7.5 A	9.5 A	10.0 A		
Noise level ⁵	55 dB		59 dB	61 dB			
Exhaust heat quantity	3500 kJ/h (836 kcal/h)		4000 kJ/h (955 kcal/h)	5040 kJ/h (1204 kcal/h)			

¹ The performance values are based on IEC 60068-3-5:2001, JTM K07:2007 for the temperature chamber, IEC 60068-3-6:2001, JTM K09:2009 for the humidity chamber. Performance figures are given for a +23°C ambient temperature, 65% rh, rated power supply and no specimens inside the test area. However, the lowest attainable temperature is given for a max. ambient temperature of +30°C. Heat-up time is the achieved time from lowest temperature to highest temperature within temperature range.

² Excluding protrusions.

³ At ambient temperature +23°C. For SH-641/661, make sure to check the power capability of your installation beforehand.

⁴ Compliance with CE Marking.

⁵ Measurements are to be taken in an anechoic room at a height of 1.2m from the floor and a distance of 1m from the chamber front panel (ISO 1996-1:2003 _ A-weighted sound pressure level)

Model		SU-221	SU-241	SU-261	SU-641	SU-661	
System		Balanced Temperature Control system (BTC system)					
Temp. performance ¹	Temp. range	-20 to +150°C (-4 to +302°F)	-40 to +150°C (-40 to +302°F)	-60 to +150°C (-76 to +302°F)	-40 to +150°C (-40 to +302°F)	-60 to +150°C (-76 to +302°F)	
	Temp. fluctuation	±0.3°C (-20 to +100°C) ±0.5°C (+100.1 to +150°C)	±0.3°C (-40 to +100°C) ±0.5°C (+100.1 to +150°C)	±0.3°C (-60 to +100°C) ±0.5°C (+100.1 to +150°C)	±0.3°C (-40 to +100°C) ±0.5°C (+100.1 to +150°C)	±0.3°C (-60 to +100°C) ±0.5°C (+100.1 to +150°C)	
	Temp. gradient / Temp. variation in space	2.5°C (-20 to +100°C) 4.0°C (+100.1 to +150°C)	2.5°C (-40 to +100°C) 4.0°C (+100.1 to +150°C)	2.5°C (-60 to +100°C) 4.0°C (+100.1 to +150°C)	2.5°C (-40 to +100°C) 4.0°C (+100.1 to +150°C)	2.5°C (-60 to +100°C) 4.0°C (+100.1 to +150°C)	
	Temp. rate of change	Heat up rate	3.2°C /min.	3.2°C /min.	3.2°C /min.	2.9°C /min.	2.9°C /min.
		Pull down rate	2.1°C /min.	2.1°C /min.	2.1°C /min.	1.7°C /min.	1.7°C /min.
	Heat up time	From -20 to +150°C within 55 min.	From -40 to +150°C within 60 min.	From -60 to +150°C within 70 min.	From -40 to +150°C within 70 min.	From -60 to +150°C within 80 min.	
	Temp. extreme achievement time Pull down time	From +20 to -20°C within 20 min.	From +20 to -40°C within 50 min.	From +20 to -60°C within 70 min.	From +20 to -40°C within 60 min.	From +20 to -60°C within 90 min.	
	Lowest attainable temp.	-20°C	-40°C	-60°C	-40°C	-60°C	
Construction	Heater	Nichrome strip wire heater					
	Refrigeration unit	System	Mechanical single-stage refrigeration system		Mechanical cascade refrigeration system		
		Cooler	Plate fin cooler				
	Refrigerator	Hermetically sealed compressor, Air-cooled condenser, Expansion mechanism: Capillary tube system					
	Refrigerator capacity	400W		[Unit 1: 400W × 1, unit 2: 400W × 1]			
Refrigerant	R404A		R23, R404A				
Capacity	22.5 L			64 L			
Chamber total load resistance	20 kg						
Inside dimensions mm (inch) ²	W300×H300×D250 (W11.81×H11.81×D9.84)			W400×H400×D400 (W15.75×H15.75×D15.75)			
Outside dimensions mm (inch) ²	W440×H560×D695 (W17.32×H24.8×D27.36)		W440×H620×D785 (W17.32×H24.41×D30.91)	W540×H660×D920 (W21.26×H25.98×D36.22)			
Weight	78 kg (73 for 100V type)		100 kg	123 kg			
Utility requirements	Allowable ambient conditions	+5 to +35°C (+41 to +95°F)					
	Power supply ³	100V AC 1φ 50/60Hz	11.0 A		15.0 A	18.0 A	
		115V AC 1φ 60Hz	10.5 A		14.5 A	—	
		200V AC 1φ 50/60Hz	—		—	10.5 A	
		220V AC 1φ 50/60Hz	7.0 A		9.5 A	10.0 A	
		220V AC 1φ 60Hz ⁴	7.0 A		9.5 A	10.0 A	
		230V AC 1φ 50Hz ⁴	6.5 A		9.5 A	10.0 A	
Noise level ⁵	55 dB		59 dB	61 dB			
Exhaust heat quantity	3500 kJ/h (836 kcal/h)		4000 kJ/h (955 kcal/h)	5040 kJ/h (1204 kcal/h)			

¹ The performance values are based on IEC 60068-3-5:2001, JTM K07:2007 for the temperature chamber. Performance figures are given for a +23°C ambient temperature, 65%rh, rated power supply and no specimens inside the test area. However, the lowest attainable temperature is given for a max. ambient temperature of +30 °C. Heat-up time is the achieved time from lowest temperature to highest temperature within temperature range.

² Excluding protrusions.

³ At ambient temperature +23°C. For SU-641/661, make sure to check the power capability of your installation beforehand.

⁴ Compliance with CE Marking.

⁵ Measurements are to be taken in an anechoic room at a height of 1.2m from the floor and a distance of 1m from the chamber front panel (ISO 1996-1:2003 _ A-weighted sound pressure level)

TEMPERATURE & HUMIDITY CONTROL RANGE (SH)

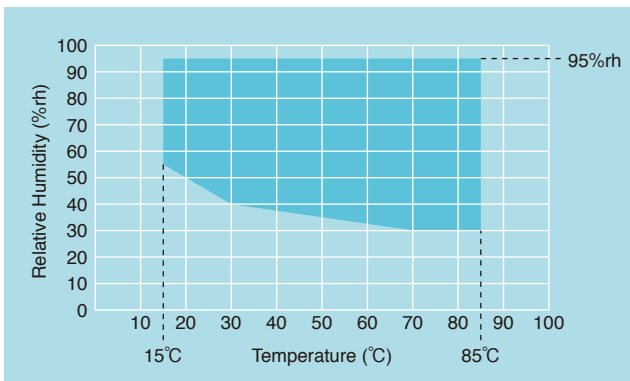

* At ambient temperature +23°C

MODEL

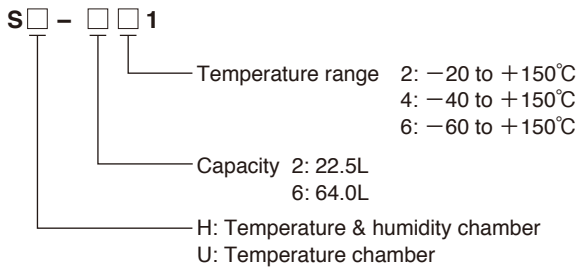

SAFETY DEVICES

- Leakage breaker
- Thermal fuse
- Boil dry protector (SH only)
- Control circuit short-circuit protective fuse
- Overheat and overcool protector
- Temperature switch for air circulator
- Specimen power supply control terminals
- Refrigerator overload relay
- Refrigerator high pressure switch
- Chamber door switch
- Upper and lower temperature (& humidity) limit alarms (Built-into temperature [humidity] controller)
- Burn-out detection circuit (Built-into temperature [humidity] controller)
- Watchdog timer (Built-into temperature [humidity] controller)
- Refrigerator automatic delay circuit (Built-into temperature [humidity] controller)

FITTINGS

- Temperature-Humidity recorder terminal
- Specimen power supply control terminal
- External alarm terminal
- External output terminal
- Cable port
- Power cable
- Drain hose
- Water supply tank (SH only)
- Humidifying tray drain plug (SH only)
- Drain socket for water sensor box (SH only)

ACCESSORIES

- Shelf 1
 - Capacity
 - SH/ SU-221, 241, 261 : 500g
 - SH/ SU-641, 661 : 5kg
 - Max. number of shelves
 - SH/ SU-221, 241, 261 : 5 (Shelf pitch 35mm)
 - SH/ SU-641, 661 : 5 (Shelf pitch 50mm)
- Connector
 - 2P for connecting terminal for temp. & humid. recorder SH:2/ SU:1
 - 6P for connecting signal terminal 1
- Cable port plug (φ 25mm) 2
- Cartridge fuse (Class A, 250V, 3A) 1
- Socket adapter (100V, 115V on 20L type only) 1
- Wet-bulb wick (Box of 24pcs) 1 (SH only)
- Humidifying tray drain hose 2m 1 (SH only)
- Drain hose for water sensor box 0.3m 1 (SH only)
- User's manual (CD-R, booklet) 1 set

DIMENSIONS

unit:mm (inch)

● SH-221·241

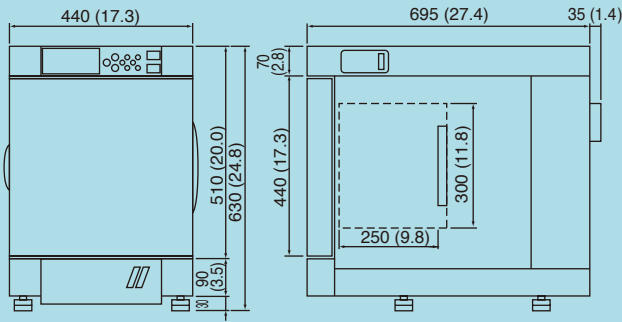
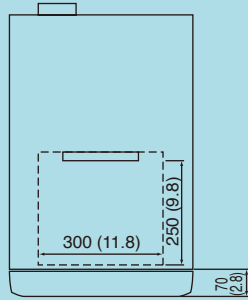

● SH-261

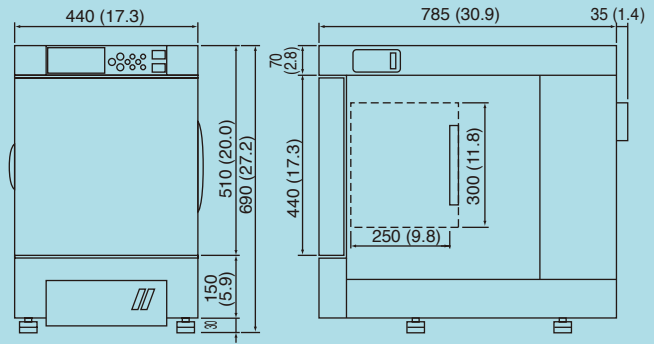
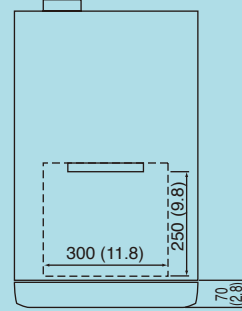

● SH-641·661

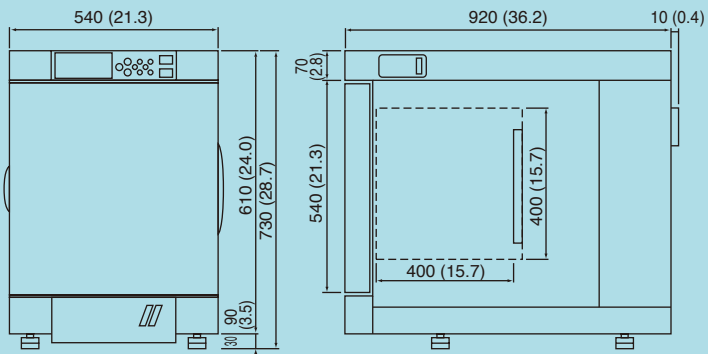
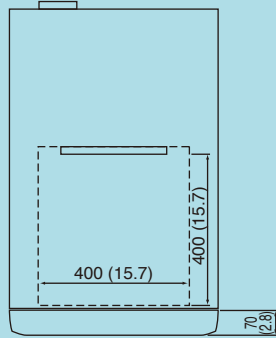

DIMENSIONS

unit:mm (inch)

● SU-221•241

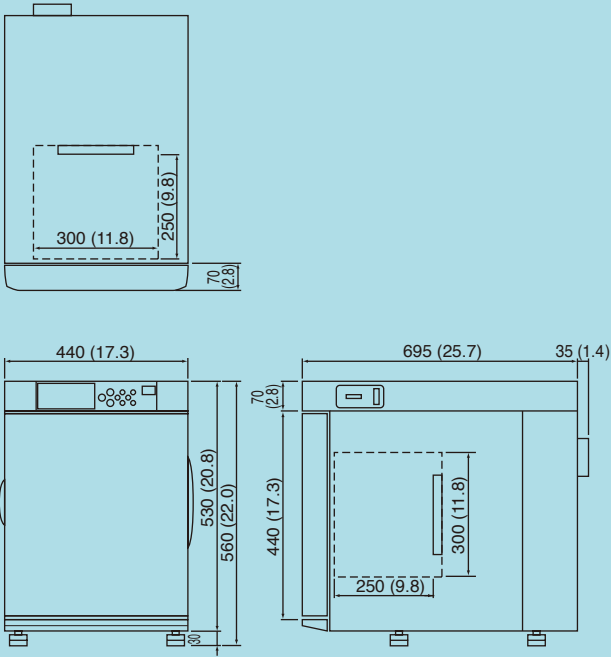

● SU-261

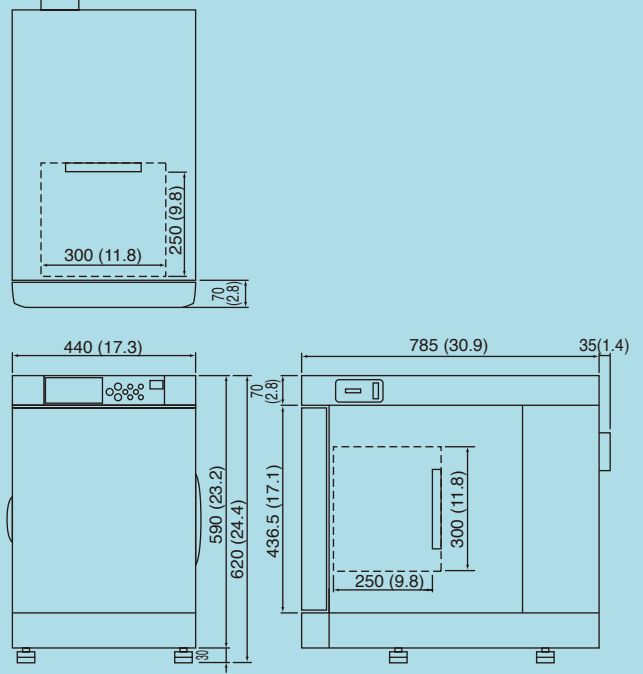

● SU-641•661

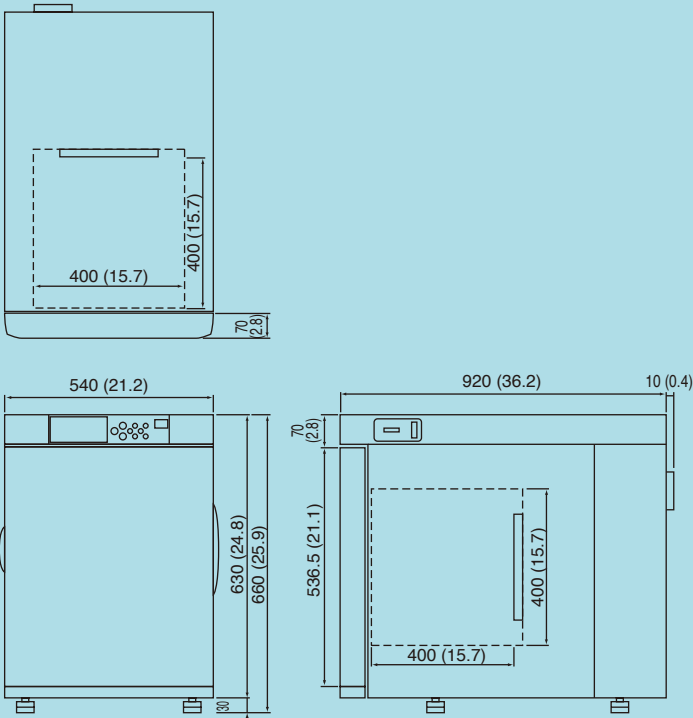

OPTIONS

Paperless recorder (Portable type)

Records temperature of each section such as the temperature inside the chamber.

Data saving cycle: 5 sec

Portable type

External recording media:

CF memory card (256MB)

USB port

Language support: ENG, JPN

[Temperature type]

Temperature range: -100 to $+200^{\circ}\text{C}$

Number of inputs (Initial setting):

Temperature 1

(5 more channels can be turned ON)

[Temperature and humidity type]

Temperature range: -50 to $+150^{\circ}\text{C}$

-100 to $+150^{\circ}\text{C}$

Humidity range: 0 to 100%rh

Number of inputs (Initial setting):

Temperature 1 / Humidity 1

(4 more channels can be turned ON)



Paperless recorder Portable type

Temperature recorder (Portable type)

[SRJ25]

Temperature range: -100 to $+200^{\circ}\text{C}$

Effective recording chart width:

100mm

Number of inputs: Temperature 6

Temperature & humidity recorder (Portable type)

Effective recording chart width:

100mm

Number of inputs: Temperature 5

Humidity 1

[SRJ14]

Temperature range: -100 to $+150^{\circ}\text{C}$

Humidity range: 0 to 100%rh (for SH)

[SRJ12]

Temperature range: -50 to $+150^{\circ}\text{C}$ /

Humidity range: 0 to 100%rh (for SH)



Wet-bulb temperature detecting terminal

For the test area wet-bulb temperature detection. A thermocouple type T (Copper/Copper-Nickel) or of equivalent thermoelectric capacity is used. Connector included.

* Not available for SU.

Thermocouple

Attached to specimens to measure specimen temperature.

• 2m

• 4m

• 6m

* Thermocouple type T without ball (Copper / Copper-Nickel)

* Same as accessory items

Viewing window

SH/SU-221, 241, 261 W215×H215mm

SH/SU-641, 661 W215×H315mm

When equipped with a viewing window, chamber performance are as follow:

Temperature uniformity :

$\pm 1.0^{\circ}\text{C}$ (-20 to $+100^{\circ}\text{C}$)

$\pm 1.5^{\circ}\text{C}$ (-100.1 to $+150^{\circ}\text{C}$)

Humidity uniformity : $\pm 5.0\%$ rh

Temp. heat up rate:

Std rate +10 min. (or less)

Temp. pull down rate:

Std rate +10 min. (or less)

($+20$ to -35°C)

Std rate +30 min. (or less)

($+20$ to -60°C)



W215×H215mm

Inner door

Glass door provided inside the chamber, to observe the conditions of the specimens.

* A wiper is included for SH models.

* This option is not compatible with a viewing window or right-opening door.

* Used for observation of the specimens inside the chamber.



SU model

OPTIONS

Right-opening door

Door can be changed for a reverse one (hinges on the right, handle on the left)
* This option is not compatible with inner glass door option.



Additional cable port

Provided in addition / replacement of the standard cable ports.

- 25mm diameter
- 50mm diameter
- 100mm diameter
- Flat cable port (W100×H25mm)

* Each cable port is equipped with a silicone sponge rubber plug.

* Basic specification of the chamber may not be met when equipped with a cable port.



25mm diameter type

flat type

Cable port rubber plug

Prevents air leakage from the cable port.

Auxiliary water tank circuit (SH)

Used to automatically refill the standard tank with the auxiliary water tank.

Required water quality:

Conductivity 0.1 to 10 μ S/cm

Water supply pressure:

4.9 to 19.6KPa (Gauge)

Auxiliary water tank (SH)

Used to refill the standard tank.

Tray for auxiliary tank (SH)

Prevents water leakage during standard tank refill process.

Shelf

Equivalent to standard accessory:

<SH/SU-221, 241, 261>

Effective size: W200×D150mm

Load resistance: 500gr.

<SH/SU-641, 661>

Effective size: W300×D300mm

Load resistance: 5kg.

Specimen basket

Equivalent to standard accessory.

Material: Stainless steel (5 mesh)



Stand

Enhances the mobility of the chamber, and facilitates load/ unload of specimens.

L stand can fit under the H stand to save space.

* Be sure to secure the stand to the floor with the provided anchor bolts.

• L stand

SH/SU-221, 241:

W440×H450×D750mm (25kg)

SH/SU-261:

W440×H390×D750mm (21.5kg)

SH/SU-641, 661:

W540×H350×D860mm (28kg)

• H stand

SH/SU-221, 241, 261:

W630×H1140×D815mm (36kg)

SH/SU-641, 661:

W730×H1140×D925mm (40kg)



L stand



Two chambers stacked
(L and H stands)

■ Some photographs listed in this catalog contain Japanese display.

■ This product can be customized for your needs. For further information, please contact us.

OPTIONS

Interface

- GPIB
- RS-232C

* Select one, instead of standard RS-485

Communication cables

- RS-485 5m/ 10m/ 30m
- GPIB 2m/ 4m
- RS-232C 1.5m/ 3m/ 6m



Safety precautions

- Do not use specimens which are explosive or inflammable, or which contain such substances. To do so could be hazardous, as this may lead to fire or explosion.
- Do not place corrosive materials in the chamber. If corrosive substances or liquid is used, the life of the unit may be significantly shortened specifically because of the corrosion of stainless steel, resin and silicone materials.
- Do not place life forms or substances that exceed allowable heat generation.
- Be sure to read the user's manual before operation.

ESPEC CORP. <http://www.espec.co.jp/english>

Head Office

3-5-6, Tenjinbashi, Kita-ku, Osaka 530-8550, Japan
Tel: 81-6-6358-4741 Fax: 81-6-6358-5500

ESPEC NORTH AMERICA, INC.

Tel: 1-616-896-6100 Fax: 1-616-896-6150

ESPEC EUROPE GmbH

Tel: 49-89-1893-9630 Fax: 49-89-1893-96379

ESPEC (CHINA) LIMITED

Tel: 852-2620-0830 Fax: 852-2620-0788

ESPEC ENVIRONMENTAL EQUIPMENT (SHANGHAI) CO., LTD.

Head Office

Tel: 86-21-51036677 Fax: 86-21-63372237

BEIJING Branch

Tel: 86-10-64627025 Fax: 86-10-64627036

TIANJIN Branch

Tel: 86-22-26210366 Fax: 86-22-26282186

GUANGZHOU Branch

Tel: 86-20-83317826 Fax: 86-20-83317825

SHENZHEN Branch

Tel: 86-755-83674422 Fax: 86-755-83674228

SUZHOU Branch

Tel: 86-512-68028890 Fax: 86-512-68028860

ESPEC TEST TECHNOLOGY (SHANGHAI) CO., LTD.

Tel: 86-21-68798008 Fax: 86-21-68798088

ESPEC SOUTH EAST ASIA SDN.BHD.

Tel: 60-3-8945-1377 Fax: 60-3-8945-1287



ISO 9001/JIS Q 9001

Quality Management System Assessed and Registered

ESPEC CORP. has been assessed by and registered in the Quality Management System based on the International Standard ISO 9001:2008 (JIS Q 9001:2008) through the Japanese Standards Association (JSA).

* Registration : ESPEC CORP.
(Overseas subsidiaries not included)

ISO 14001 (JIS Q 14001)

Environmental Management System Assessed and Registered

ESPEC CORP.