

# TOS9000

## WITHSTANDING VOLTAGE AND INSULATION RESISTANCE TESTER



**Withstanding Voltage Tester: AC 5 kV/40 mA (transformer capacity: 500 VA)**

**Insulation Resistance Tester: DC 50 to 1000 V, 1M to 9999 M $\Omega$**

**Can be combined with peripherals to build the TOS9000 Automatic Testing System**

### Outline

The Model TOS9000 automatic withstanding voltage and insulation resistance tester is an automatic tester equipped with two functions for withstanding voltage testing and insulation resistance testing. Combining with the Model TOS6200 Earth Continuity Tester through GPIB enables performing of three types of tests in a single step.

The withstanding voltage tester has performance of a maximum output of 5 kV (4 kV when used with the Model TOS9020 High Voltage Scanning Unit) and transformer capacity of 500 VA. The insulation resistance tester is equipped with a test voltage of 50 to 1000 V and measuring range of 1M to 9999 M $\Omega$ . In addition, test parameters and test processes can be programmed and stored in memory using the data entry keys, cursor/scroll keys and fluorescent display on the front panel as a result of being equipped with a CPU. There is no need to reset test parameters each time testing is performed since the desired test parameters can be set with a single remote control operation. Settings can naturally also be recalled by remote control thus significantly promoting greater automation and efficiency in testing. Moreover, since the TOS9000 comes with built-in GPIB interface as standard feature, it enables the construction of fully automated system operated by computer.

### Features

#### ■ GPIB Control

Setting of test parameters, start/stop control and so on can be controlled with simple GPIB commands from an external computer. In addition, tester status, test results, measured values and other data can be transferred from the TOS9000 to the computer.

#### ■ Sequence Control

Each of the withstanding voltage, insulation resistance and low ohm tests can be combined as desired from the panel of the TOS9000 for continuous testing. A maximum of 98 steps of continuous testing can be programmed. During performing the tests, each step memory will proceed in sequentially from [1] to [98] simply by recalling the program and pressing the start button.

#### ■ Manual Control

Since each of the settings for withstanding voltage, insulation resistance and AC low ohm testing can be stored in memory for up to 10 sets of test parameters set in independent testing, there is no need to reset test parameters each time testing is performed. The desired test parameters can be set with a single remote control operation.

## WITHSTANDING VOLTAGE AND INSULATION RESISTANCE TESTER

### Functions

#### ■ Memory Function and Program Function

Up to 10 sets of test parameters set for individual tests can be stored in memory. In addition, in the automatic testing mode, the withstanding voltage, insulation resistance and low resistance tests can be combined as desired, and then programmed into a continuous test process containing a maximum of 98 steps. Up to 15 types of programs can be stored in memory (total of 480 steps).

Even when the testpieces on the production line are different or different standards are applied for individual tests, the use of this memory function and program function allows setting of the desired test parameters simply by performing a recall operation without having to reset parameters for each test or standard.

#### ■ Remote Control Function

This function allows "start/stop control" (output on/off control) of individual tests as well as "start/stop control" or "start/stop control and program selection" of automatic testing from an external device. A +15V power supply as well as a separate power supply are available for the remote control power supply.

In addition, in the case of controlling with an optional remote control box (RC01-TOS or RC02-TOS) or high-voltage test probe (HP01A-TOS or HP02A-TOS), a special-purpose connector (5 pin DIN connector) is provided on the operating panel that allows these options to be connected directly to the TOS9000.

#### ■ Signal Output Function

A total of 14 types of output signals, including PASS, FAIL and READY signals, are available for external detection of device status and upgrading the system.

There are four kinds of signals consisting of open collector, lamp, buzzer and AC100V output (signal contents vary according to the type of signal). Combining of these signal outputs with the remote control function results in greater automation and efficiency in testing.

#### ■ Memory Backup Function

Since data from tests that are in progress is stored in memory and not lost even if the power is interrupted, there is no need to repeat the setting operation when the power is turned back on, thereby allowing testing to be restarted immediately.

#### ■ GPIB Interface

Setting of test parameters along with control of starting and stopping can be performed using simple GPIB commands. In addition, since both set values and measured values can also be read, a GPIB test system can be put together that includes data processing of test results.

Listener Function	<ul style="list-style-type: none"> <li>·Starting and stopping control of independent testing</li> <li>·Setting of test parameters of independent testing</li> </ul>
Talker Function	<ul style="list-style-type: none"> <li>·Readout of device status and test results</li> <li>·Readout of measured values</li> </ul>
Service Request	<ul style="list-style-type: none"> <li>·Generation of PASS, FAIL and protection signals</li> </ul>

#### ■ Interlock Mechanism

An interlock mechanism is provided as one of the measures that have been employed to ensure the safety of operation. When the interlock mechanism is activated, the TOS9000 generates a protection signal which prevents it from being operated. In addition, if the interlock mechanism is activated during testing, the output is interrupted and testing is terminated.

#### ■ Protective Function

In addition to the interlock mechanism described above, the TOS9000 is also equipped with a protective function which notifies the operator of a failure or abnormality in the TOS9000 or of an error in the operation of any peripheral units such as the scanning unit on AC low ohm tester. When the protective function of the TOS9000 is activated, the location where the protective function was activated is displayed on the display, thereby facilitating determination of the cause of the problem.

#### ■ Key Lockout Function

This function is for preventing inadvertent alteration of the test parameters and other data settings, as well as the performing of testing under erroneous parameters. It is designed such that only the START/STOP buttons can be pressed, with all other keys being made inoperable.

#### ■ Output Voltage Trip Function

This function is for preventing an excessively high voltage being output by mistake caused by a setting error. It prevents the setting of any other voltages once the standard voltage has been set.

#### ■ Message Function

Various messages are displayed on the display corresponding to the status of the TOS9000 for improved operation efficiency. With respect to test results in particular, information pertaining to a description of the failure when a judgement of FAIL is made are also displayed on the display. Together with reducing the amount of time spent on processing of defective products, this function is also effective in quantitative monitoring of the causes of defects.

In addition, "Incorrect" will be displayed when data has been mistakenly entered outside of the setting range during setting of data. Data entry in this case will not be accepted by the TOS9000. This serves to minimize the occurrence of setting errors.

# TOS9000

## WITHSTANDING VOLTAGE AND INSULATION RESISTANCE TESTER

### Peripherals

The TOS9000 can be combined with the peripheral and a computer to construct the "TOS9000 System", an automatic testing system able to handle a wide range of testing situations.

#### ■ Model TOS9020 High-Voltage Scanning Unit

This high-voltage scanning unit is equipped with a contact check function having output terminals for 4 channels. Controlled by the TOS9000, this unit can scan a maximum of 4 testing points by switching the connection with the H.V./LOW output terminal of the TOS9000 as desired.

- Performs withstanding voltage and insulation resistance tests by setting a high voltage side and low voltage side for each of any two points between 4 testing points (multiscan).
- By fixing the LOW terminal available for single scanning at the low voltage side, a high voltage can be distributed among 4 testing points with the low voltage point serving as the reference (single scan).
- Scanning can be expanded to a maximum of 16 channels by connecting up to 4 scanning units in parallel to a single TOS9000.

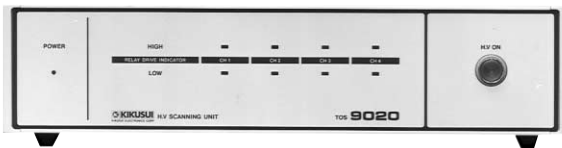

### System Configuration Example

TOS9000 system configuration containing one Model TOS9000 Automatic Withstanding Voltage and Insulation Resistance Tester plus Model TOS9020 High-Voltage Scanning Unit.

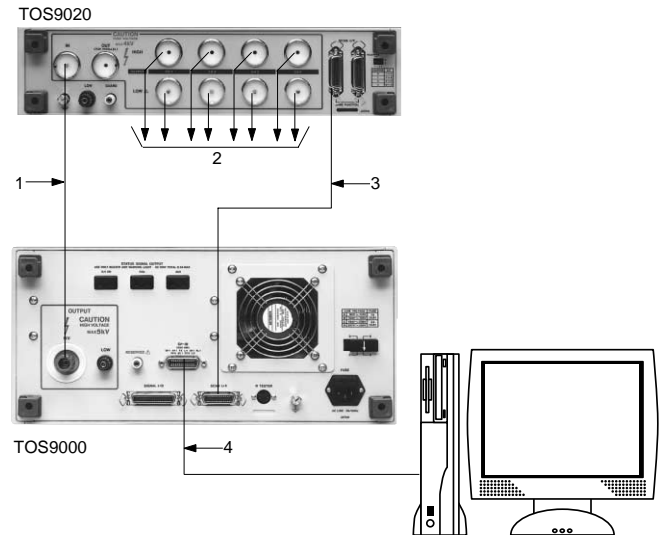

Necessary Equipment for System Configuration		
1	<input type="radio"/>	High-Voltage Shielded Cable *1
2	<input type="radio"/>	High-Voltage Shielded Cable (HC03-TOS) *1
3	<input type="radio"/>	24P Amphenol Connector (with cable, length:1m) *1
4	<input checked="" type="radio"/>	GPIB Cable

(  : Standard accessory     : Sold separately )

\*1:Standard accessory of TOS9020

## WITHSTANDING VOLTAGE AND INSULATION RESISTANCE TESTER

### Applications

(1) Testing of a Testpiece having a Multiple Number of Testing Points such as a Switching Power Supply Using the Scanning Unit

- The Model TOS9020 High-Voltage Scanning Unit is able to sequentially scan and output testing points thereby allowing the performing of tests between all testing points in a single process.
- Even in cases when the contents of a test vary depending on the testing point, by programming the testing parameters in advance, testing can be performed continuously.

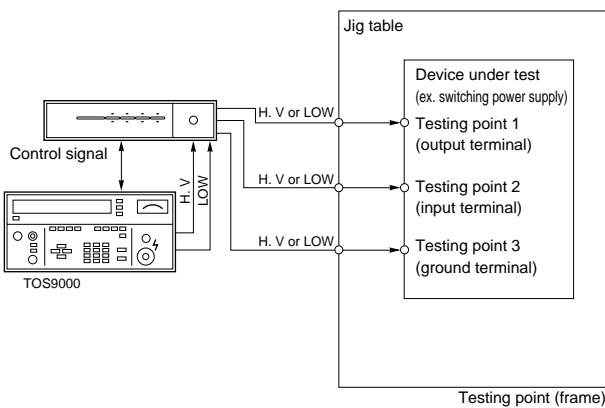

(2) Small-Scale Automatic Testing System Using Program and Remote Control Function plus Signal Output Function

- Allows system configuration without using a computer.
- Use of the program and remote control functions of the TOS9000 allow the testing process to be selected automatically corresponding to the specific testpiece.
- By using the signal output function of the TOS9000, the status of the TOS9000 can be monitored at the conveyor side and sorting of the testpieces can be performed automatically according to judgement results.

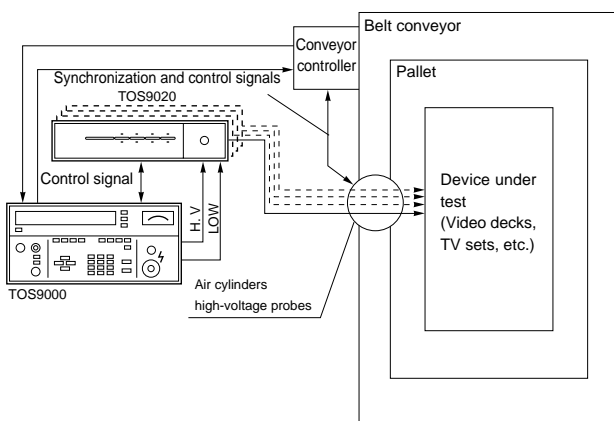

(3) Unmanned Automatic Testing System Using a Computer and the I/O Unit

- The GPIB interface function of the TOS9000 allows the performing of testing following setting of test parameters from a computer.
- Test results can be managed and tabulated using the computer.

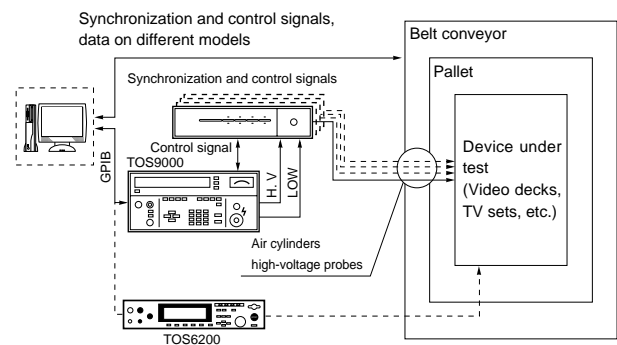

(4) Unmanned Automatic Testing System for Mixed Lines Using a Robot

- Automatic testing can be performed on mixed lines for a multiple number of models by control of a robot (X-Y table, etc.).
- Use of the GPIB interface function of the TOS9000 allows tests to be performed by setting test parameters from the computer.
- Test results can be managed and tabulated using the computer.

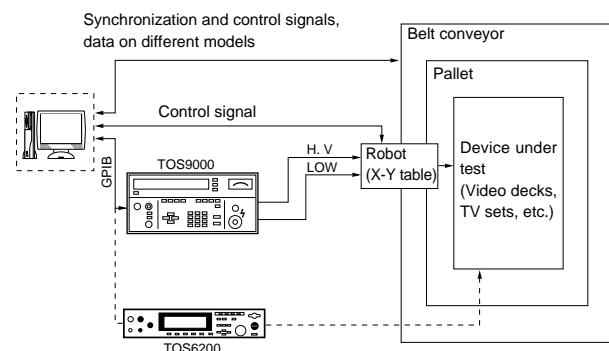

# TOS9000

## WITHSTANDING VOLTAGE AND INSULATION RESISTANCE TESTER

### Specifications

#### ■ Withstanding Voltage Tester Section

<input type="checkbox"/> Test Voltage	
Output Voltage	0.20 to 5.00 kV AC (digital setting, 3 digits), 10V steps, adjustable with UP/DOWN keys
Maximum Voltage	200 VA/5 kV, 40 mA with time limit (refer to Note 1)
Transformer Capacity	500 VA
Voltage Setting Accuracy	±(2% of setting + 2 digits) (without load)
Waveform	Sine wave (distortion factor at maximum output with resistance load: ≤0.5%)
Voltage Regulation	5% or better with respect to change from rated load (5 kV/40 mA) to no load)
Output Circuit	Linear amplifier
<input type="checkbox"/> Output Voltmeters	
Analog Display	
Scale	5 kV full scale, linear scale
Class	JIS Class 1.5
Accuracy	±3% of full scale
Indication	Mean-value response, effective-value scale graduation
Digital Display	
Accuracy	±(5% of reading + 10V)
<input type="checkbox"/> Output Milliammeter	
Accuracy	±(5% of upper cutoff current + 20μA)
<input type="checkbox"/> Pass/fail Judgement	
Type of Judgement	*Window comparator type *A FAIL judgement is made when a current greater than the upper cutoff current or smaller than the lower cutoff current is detected. *When a FAIL judgement is made, the output voltage is cut off and a FAIL alarm signal is delivered. *If no abnormal state is detected during the test time, a PASS judgement is made and a PASS signal is delivered.
Limit Value Setting Ranges	Upper cutoff current: 0.10 to 40.0 mA Lower cutoff current: 0.05 to 39.0 mA (digital setting, 3 digits)
Judgement Accuracy	±(5% of upper cutoff current + 20 μA) (Refer to notes 2 and 3)
Measurement Calibration	Integration of absolute value of current With rms value of sine wave using a pure resistance load
<input type="checkbox"/> Test Time	0.5 to 99.9 s (±10 ms) (timer-off function provided)

Note 1: Allowable output delivery time (test time)

\*When the upper limit current for Pass/fail judgement is not greater than 20 mA:

Can be continuously delivered (at an ambient temperature not higher than 40°C)

\*When the upper limit current for Pass/fail judgement is 20.1 mA to 30 mA:

Up to 100 sec. (at an ambient temperature not higher than 40°C)

\*When the upper limit current for Pass/fail judgement is 30.1 mA to 40 mA:

Up to 50 sec. (at an ambient temperature not higher than 35°C)

The heat dissipation capacity of the high-voltage generator section of this tester is designed to be only 1/2 with respect to the rated output in consideration of size, weight and costs. Thus, in the case of performing testing at a value for which the judgement reference value exceeds 20 mA, allow a pause period equal to or greater than the test period. The allowable limit of output delivery time (test time) is as shown above for ambient temperatures up to 40°C when the upper limit reference value is not greater than 30 mA, or for ambient temperatures up to 35°C when the upper limit reference value exceeds 30 mA.

#### ■ Insulation Resistance Tester Section

<input type="checkbox"/> Measuring Voltage	
Voltage Setting Range	50 to 1000V DC, negative polarity (digital setting, 1V steps)
Setting Accuracy	±(2% of setting + 2V)
Measuring Terminal	Constant voltage satisfying the Voltage setting accuracy
<input type="checkbox"/> Measuring Range	1M to 9999 MΩ
Measuring Accuracy	±5% of reading at 500V and 1 to 2000 MΩ
<input type="checkbox"/> Pass/fail Judgement	
Type of Judgement	*Window comparator type *A FAIL judgement is made when a current greater than the upper cutoff current or smaller than the lower cutoff current is detected. *When a FAIL judgement is made, the output voltage is cut off and a FAIL alarm signal is delivered. *If no abnormal state is detected during the test time, a PASS judgement is made and a PASS signal is delivered.
Limit Value Setting Range	Both upper and lower cutoff current can be set arbitrarily within the measuring range
Judgement Accuracy	Same as measuring accuracy (at 500V and 1 to 1000 MΩ)
Judgement Waiting-Time	0.3 s (can be varied between 0.3 to 10 s)
<input type="checkbox"/> Test Time	0.5 to 99.9 s (±20 ms) (Timer-off function provided)
<input type="checkbox"/> Overall Specifications	
<input type="checkbox"/> Test Modes	
AUTO	*Up to 98 test steps with different test parameters for respective steps can be programmed for each test program.
MANU. W	*Up to 15 test programs can be stored (total of 480 steps).
MANU. I	*Execution of withstanding voltage test only (test voltage can be changed with the UP/DOWN keys during testing).
MANU. R	*Execution of insulation resistance test only
<input type="checkbox"/> GPIB Interface	*Test commands can be given to the TOS6100 earth continuity tester. (refer to Note 4)
<input type="checkbox"/> Remote Control	*Start/stop control of individual tests *Setting of test parameters of individual tests *Start/stop control *Selection of test program *Interlock function *Isolated power supply

Note 2: When the TOS9020 High-Voltage Scanning Unit is used in combination with this tester, the accuracy of judgement is as follows: ±(5% of upper limit reference value + 100 mA)

Note 3: The stray capacity of the measurement lead wire or jig will cause inaccuracy in leak current measurement during actual testing. For the overall judgement accuracy of the test, the factor reflecting the above inaccuracy should be added to the judgement accuracy given in the specifications. When testing is performed at high sensitivity or high voltage, the value of the current that flows through the stray capacity becomes larger than the lower limit reference value, thus making low limit judgements meaningless.

Note 4: This function is only usable when used with earth continuity tester Mode TOS6100. However the TOS6100 has been discontinued. TOS6200 earth continuity test has no provision for this function.

## WITHSTANDING VOLTAGE AND INSULATION RESISTANCE TESTER

### Specifications

#### □ Signal Output Functions

Signal Name	Signal Type			
	Open Collector	Lamp	Buzzer	AC100V
H.V ON	✓	✓		✓
PASS	✓	✓	✓	
FAIL	✓	✓	✓	✓
WU/FAIL	✓			
WL/FAIL	✓			
IU/FAIL	✓			
IL/FAIL	✓			
R/FAIL	✓			
CONTACT FAIL	✓			
READY	✓			
STEP END	✓			
CYCLE END	✓			
PROTECTION	✓	✓		
Reserved				✓

\*Open collector ratings: DC30V/400mA (maximum) in total

\*Rating of AC100V signal is 0.3 A (maximum) in total.

\*The CONTACT FAIL signal is available only when the Model TOS9020 is connected.

#### □ Other

Environment	Operating temperature: 5 to 35°C Operating relative humidity: 20 to 80% r.h.
Line Voltage	90 to 110V, 104 to 125V, 194 to 236V, 207 to 250V, 50/60 Hz
Power Consumption	Approx. 650 VA at rated load
Dimensions (MAX) and Weight	430W × 199H × 370D mm (430W × 214H × 440D mm), approx. 29 kg
Accessory	
•TL01-TOS :high voltage test lead wires, approx.1.5m (4.9ft.) long.	1
•Power cord set	1
•36P Amphenol connector plug (assembly type)	1
•5P DIN cable	1
•5P DIN cable (assembly type)	1
•"DANGER! HIGH VOLTAGE" warning sticker	1
•Operation Manual	1
•Fuse, 7A, slow blow. (in fuse holder)	1
•Fuses, 3A, slow blow	2

### TOS9020 Specifications

■ Maximum Test Voltage	4 kV AC
Number of Channels	4
Maximum Parallel Units	4(16 channels)
■ Indicators	The following indicators are provided using LED lamps. <ul style="list-style-type: none"> <li>● H.V ON: Lights linked to H.V ON lamp of the TOS9000 during testing</li> <li>● POWER: Lights linked to the POWER SW of the TOS9000</li> <li>● RELAY DRIVE INDICATORS: Light to indicate the channels set for the high and low sides during testing</li> </ul>
■ Unit Number Switches	DIP switches are used to set the unit numbers (address numbers) for each of up to four units connected in parallel. Available unit numbers are 0 to 3 (set at 0 when shipped).
■ Contact Check Function	<ul style="list-style-type: none"> <li>● In the multi-scanning mode, contacts of the HIGH line and LOW line channels are checked.</li> <li>● In the single scan mode, contact of only the HIGH line channel is checked.</li> </ul>
■ Other	
Dimensions and Weight	430W × 99(114)H × 370(410)D mm (values in parentheses indicate dimensions including projections), approx. 6 kg

#### Accessory

•24P Amphenol connector (with cable, approx. 1m or 3.3 ft. long)	1
•H.V shielded cable(with connector, for connection with TOS9000, approx. 1m or 3.3 ft. long)	1
•Instruction manual	1
•"DANGER! HIGH VOLTAGE" warning stickers	2
•Channel stickers	2 sets
•HC01-TOS cables (H.V shielded cable for parallel connection of TOS9020 units, approx. 0.5m or 1.6 ft. long)	1
•HC03-TOS cable (H.V shielded cables to connect TOS9020 unit to tested object, approx. 2m or 6.6 ft. long)	4
•Wire for connection between the LOW terminal and the shield of H.V shielded cable. (with a crimp-type terminal and a connector)	1

### Options

#### ■ Remote Control Box

RC01-TOS	One-hand operation (200W × 70H × 39D mm)
RC02-TOS	Two-hands operation (330W × 70H × 39D mm)

#### ■ High-Voltage Test Lead

TL02-TOS	Approx. 3 m
TL01-TOS	Approx. 1.5 m

#### ■ High-Voltage Test Probe

HP02A-TOS	3 m (max. operating voltage: 4kV AC/5 kV DC)
HP01A-TOS	1.5 m (max. operating voltage: 4kV AC/5 kV DC)

#### ■ High-Voltage Shielded Cable

HC01-TOS	For parallel connection of TOS9020
HC03-TOS	For parallel connection of TOS9020, and connection between TOS9020 and device under tested

#### ■ GPIB Cable

408J101	Approx. 1 m
408J102	Approx. 2 m
408J104	Approx. 4 m

#### ■ Warning Light Unit

PL01-TOS

#### ■ Buzzer Unit

BZ01-TOS

#### ■ Rack Mount Brackets

BH4M-TOS	JIS brackets for TOS9000
BH5-TOS	EIA brackets for TOS9000
BH2M-KSG	JIS brackets for TOS9020